

STRUCTA™

TOUGH WHERE IT MATTERS

INSTALLATION GUIDE

STRUCTApanel®

Smooth, Black, T&G VJ150

INTERNAL WALL PANELLING INSTALLATION

Fixing to timber, steel, plasterboard, masonry walls, ceilings and over other existing linings

Considerations

- All walls and ceilings should be straight and true for best results.
- Sheets joined on wall studs will give the best results.
- Wall stud spacing of 600mm centres maximum.
- Ceiling truss should have a spacing of 700mm centres max. with battens attached at max. 450mm spacings.
- Panels can be joined off the studs, but these joints must be supported by additional noggins at 700mm maximum spacings.
- Wall panels should NOT be to butt joined to other panels including ceiling panels. Expansion can cause the butt joint to move. If the panel is painted, the painted joint will crack. Adhere to expansion gap guidelines and conceal joints with trim, such as a dressed batten or cornice. Refer to Figure 9.
- The product should be allowed to acclimatise in the room for 48 hours prior to installation, with evenly aligned bearers to prevent sag under-pack and enable air to circulate freely.
- Never store material outdoors or in an open area (veranda), or areas with newly poured concrete or in rooms that have been recently plastered.
- The product is not designed for external or wet area applications and should be kept dry at all times.
- All wood products are hygroscopic, which means they have the ability to absorb and release moisture, causing expansion and contraction. Therefore, it's crucial to ensure that the framing, wall and ceiling cavities, and the existing wall linings where STRUCTApanel® is being installed have the appropriate moisture content.

Tools Required

- P1 or P2 Dust Mask & Safety Glasses
- Caulking Cartridge Gun or Spatula

Fixings

- **The supplier of the fixings should confirm their suitability for installation before use.**
- **When fixing into steel, screws should be used.**
- Fixings should be long enough to **penetrate at least 25 – 30mm** into the timber frame.
- Fixings should be spaced 200 – 300mm across top, bottom plates, noggins, battens, furring channels and down studs with a min. 10mm distance to the edges of the panel.
- **Nails**
 - Hammer – 2mm bullet head
 - Nail gun – 14g brad
- **Screws**
 - Into timber – 8g
 - Into steel – 8g needle point self head embedding CSK / PH2

Adhesives, Sealants and Gap Fillers

- **The supplier of adhesives, sealants, and gap fillers should confirm their suitability for installation before use.**
- **Use a flexible sealant or gap filler that can be painted and has a**

25% expansion capacity for sealing joints and filling gaps between sheets, corners, and for adhering to trims like mouldings, cornices, skirtings, architraves, and dado rails.

- **Apply generous amounts of construction adhesive** with a 25% expansion capability to attach the panel to studs, noggins, top and bottom plates placed approximately 300mm apart. When adhering to plasterboard or other wall linings, create a bead around the perimeter and a zigzag pattern down the wall.
- When installing onto battens or furring channels it is recommended to use a continuous bead in a zigzag pattern.

Expansion Gap Allowances

For walls allow:

- 5mm at wall to ceiling interface and 10mm at wall to floor interface.
- 1mm between long edge joints, **DO NOT** hard knock panels together.
- 3mm in the corners and wall intersections.
- 5mm at bottom of panel if placed on top of a skirting.
- 5mm between sheets if placed end to end with both ends supported by the stud, noggin, batten or furring channel. **Refer to Figure 9.**

For ceilings allow:

- 5mm around perimeter of ceiling.
- 1mm between long edge joints, **DO NOT** hard knock panels together.
- 5mm between sheets if placed end to end with both ends supported by the truss, batten, or furring channel. **Refer to Figure 9.**

Moisture content of wall, ceiling and existing wall linings onto which a panel is being installed

- All wood products are hygroscopic, which means they have the ability to absorb and release moisture, causing expansion and contraction. Therefore, it's crucial to ensure that the framing, wall and ceiling cavities, and the existing wall linings where VJ150 is being installed have the appropriate moisture content.
- Excessive moisture can lead to the development of mould. Employing moisture vapour barrier linings and implementing proper ventilation are commonly employed construction methods to minimise the ingress of moisture into wall or ceiling cavities.
- As ceilings, masonry and external facing walls pose a risk of higher moisture, it is advisable to seal the rear, edges, and service penetrations of the panels being installed on these surfaces.
- **As a guide, safe moisture levels are:**
 - Wall cavity relative humidity = 50%
 - Ceiling roof cavity relative humidity = 50%
 - Plasterboard = <1%
 - Other timber wall lining = <14%

Installation

Timber and Steel 450mm and 600mm Stud Frame Wall Installation [Figure 1 & Figure 2](#)

- Follow fixing, adhesive, sealant, and expansion gap requirements.
- Check frames are straight and true.
- Check studs are max. 600mm apart.
- If studs are less than 600mm apart then extra noggins need to be installed to support the joint, max. 700mm distance between the noggins.

Smooth, Black, T&G VJ150

PRODUCT INSTALLATION

- Decide how you wish to finish off internal and external corners before you install the first sheet.
- Short ends of boards should NOT be butt joined to other boards or butted wall to ceiling. Manufacturing variations can result in the grooves not lining up and well as expansion can cause the butt joint to lift.
- Start at one end or corner of the wall.
- Apply adhesive to the frame behind the first panel to be installed.
- Using 10mm spacers along the floor rest the bottom edge on the spacers, then press the panel against the wall.
- Check the first panel is straight and level, then fix it into place.
- Remove the spacers and set in place for the second panel to be installed.
- Repeat the above process for the remaining panels.
- Measure and cut the last panel to fit as required.
- Skirting, architraves, mouldings and cornice material can then be fitted.
- Seal / gap joints / full fixing head holes.

Installation onto Masonry Walls [Figure 3](#)

- Follow fixing, adhesive, sealant, and expansion gap requirements.
- Fix and level horizontal furring channels or battens to the masonry wall at max. 450mm centres, this promotes airflow behind the panel to reduce moisture uptake as well as enables the wall to be levelled if needed.
- Other installation principles are the same as fixing onto timber and steel frames.

Installation onto Ceilings [Figure 4](#)

- Follow fixing, adhesive, sealant, and expansion gap requirements.
- Install the panels across the trusses, battens, or furring channels rather than down to minimise the potential for the panel to sag.
- Ceiling trusses should be max. 700mm centres.
- Battens or furring channels should be run across the trusses at a max. 450mm spacing.
- If ceiling trusses are max. 450mm apart then the panel can be installed directly across them.
- Panels should not be installed in a brick shaped pattern.
- The ends of sheets should be installed in a line so a decorative batten or similar can be installed over the expansion gap to hide the joint.
- If installing panels end to end, the short ends of sheets should finish on a batten with a 5mm expansion gap put in place before next sheet is started. Different finishing options are available to hide this joint.

Installation over the top of Plasterboard and other existing Wall Linings [Figure 5](#)

- Follow fixing, adhesive, sealant, and expansion gap requirements.
- Check that the wall lining you are attaching to is fixed correctly to the wall frames, if not, corrective measures should be implemented.
- Ensure the surface is in good condition; a gentle sanding may be necessary to eliminate any loose material and facilitate adhesive adherence. If the surface is damaged, consider taking corrective measures before proceeding further.
- Check the flatness of the wall, if the wall is not flat you may have to consider installing battens / furring channels the same as onto masonry walls so that you can correct this.
- Use a stud finder to locate position of studs, noggins, battens, or furring channels to fix into.
- Other installation principles are the same as fixing onto timber or steel framed walls.

Installation of Panels Horizontally [Figure 6](#)

- Note the fixing, adhesive, sealant, and expansion gap requirements.
- If installing the T&G VJ150 panelling, the tongue of the panel should be positioned facing upwards. It does not require an extra row of noggins as the tongue will act as a support for the joint.
- If installing the Smooth panelling, the top of the panel should be supported by a row of noggins.
- Wall panels should NOT be butt joined to other panels. Manufacturing variations can result in the grooves not lining up and expansion can cause the butt joint to lift. Adhere to expansion gap guidelines and conceal joints with trim, such as a dressed cornice batten. **Refer to Figure 9.**
- The ends of the sheets should be supported by studs, battens, furring channels or adhesives if being installed on an existing wall.
- Other installation principles are the same as fixing onto timber or steel framed walls.

Installation of Partial Height Panels [Figure 7](#)

- Note the fixing, adhesive, sealant, and expansion gap requirements.
- A row of noggins should be placed at the top of the panel to support the short end of the panel.
- A row of noggins should be placed approx. half way between the top of the panel and the bottom.
- Other installation principles are the same as fixing onto timber, steel, or masonry walls.

Installation of Mouldings, Cornices, Skirtings and Architraves [Figure 8](#)

- Apply flexible gap filler to adhere the trim to the panel.
- Use the same nail fixings as when installing onto walls.
- Installing near Fireplaces and Heat Sources [Figure 10](#)
- Special consideration needs to be taken when installing panels near a fireplace or heat source to avoid any potential safety hazards.
- Each manufacturer of a heat source such as an oven, heater or fireplace may have different exclusion zone requirements depending on their method of construction.
- It is our recommendation to follow the manufacturer's installation recommendations in conjunction with Australian and New Zealand Standard 2918.
- The diagrams in the schematic section are examples only of some common exclusion zones.

Finishing

Painting or Staining

- The surface of the panel should be clean and free from dirt and debris. A light sanding of the surface is recommended to create a suitable "key" for the primer.
- After sanding, remove residual dust and debris with a vacuum cleaner and wipe down the wall panels with a clean damp cloth or sponge. Prior to coating check the moisture content of the board with a moisture meter. The moisture level must be below 15% prior to application.

Smooth, Black, T&G VJ150

INSTALLATION

Timber and Steel 450mm Stud Frame Wall Installation Figure 1

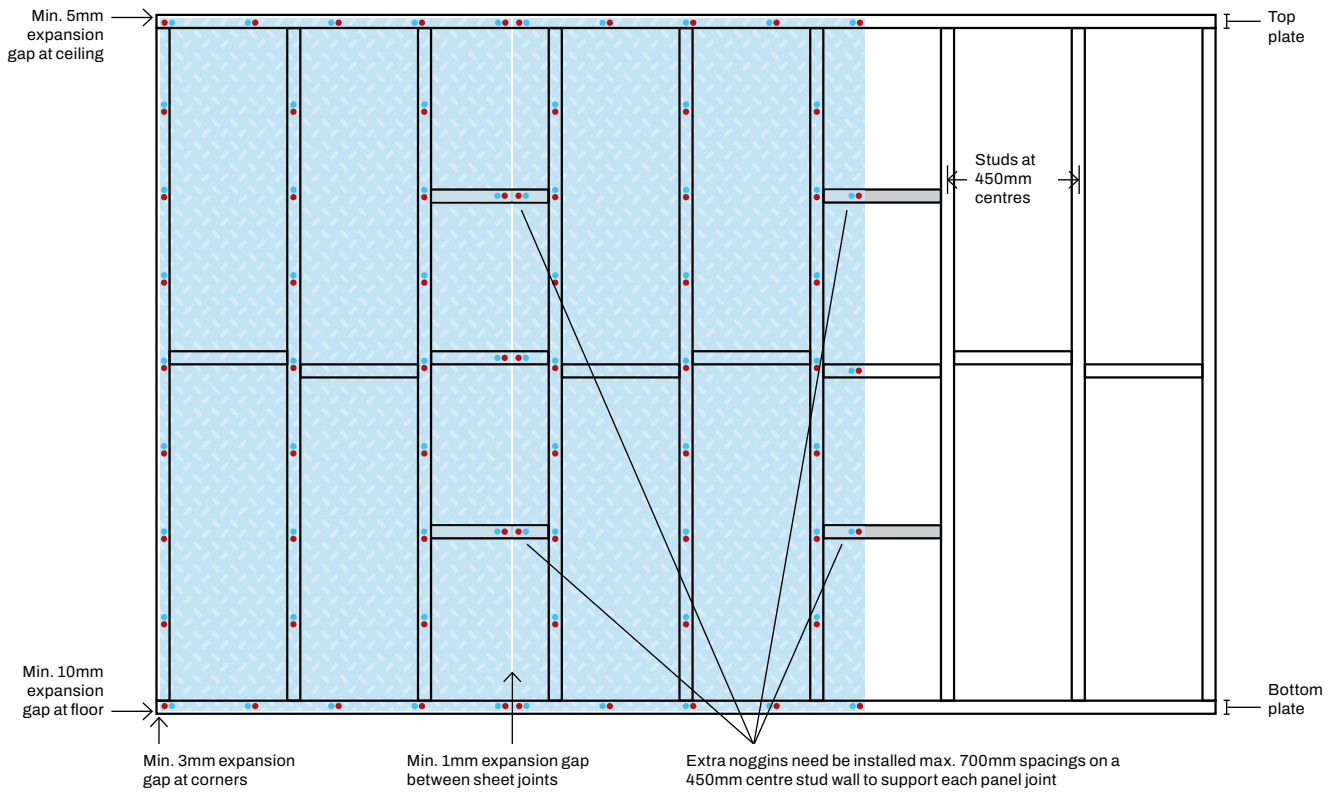

Timber and Steel 600mm Stud Frame Wall Installation Figure 2

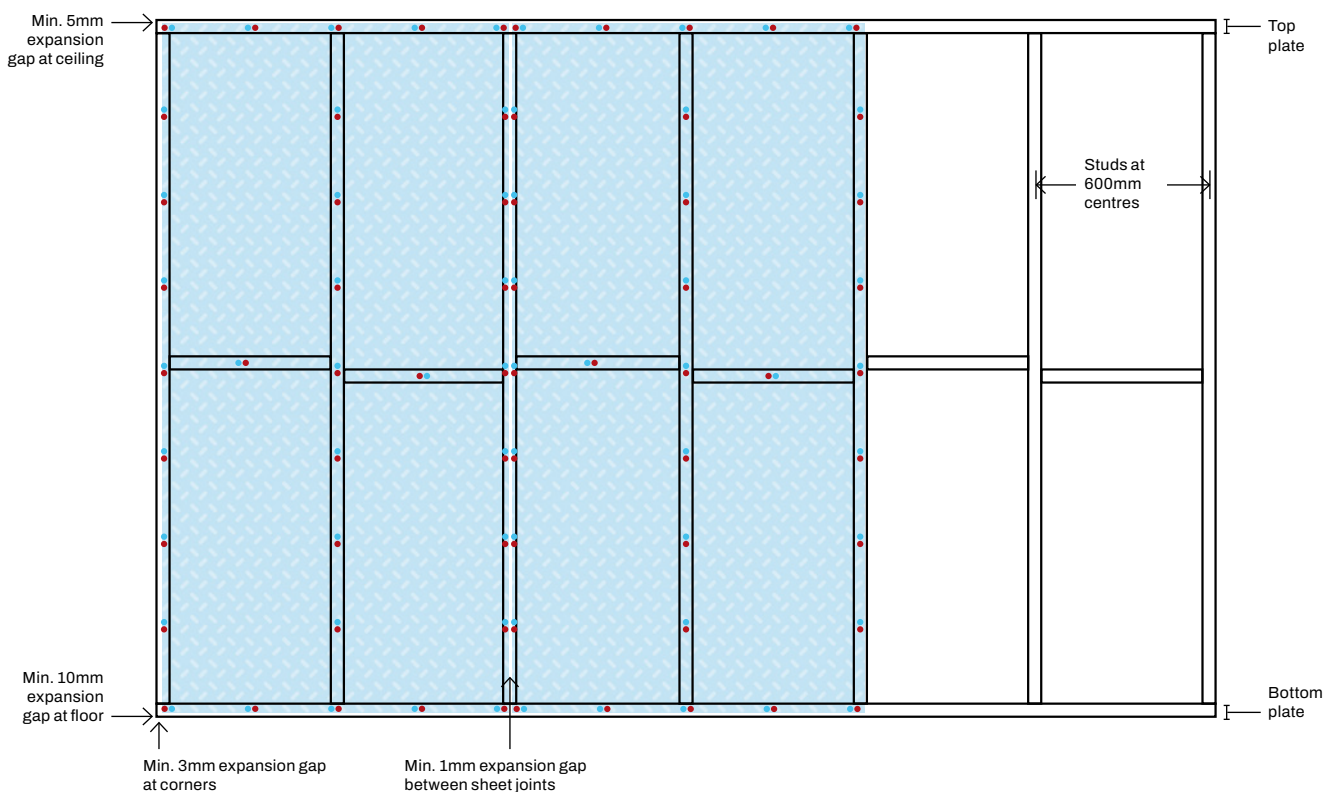

Diagram Legend

- STRUCTApanel®
- Glue
- Fixings

Smooth, Black, T&G VJ150

INSTALLATION

Installation onto Masonry Walls **Figure 3**

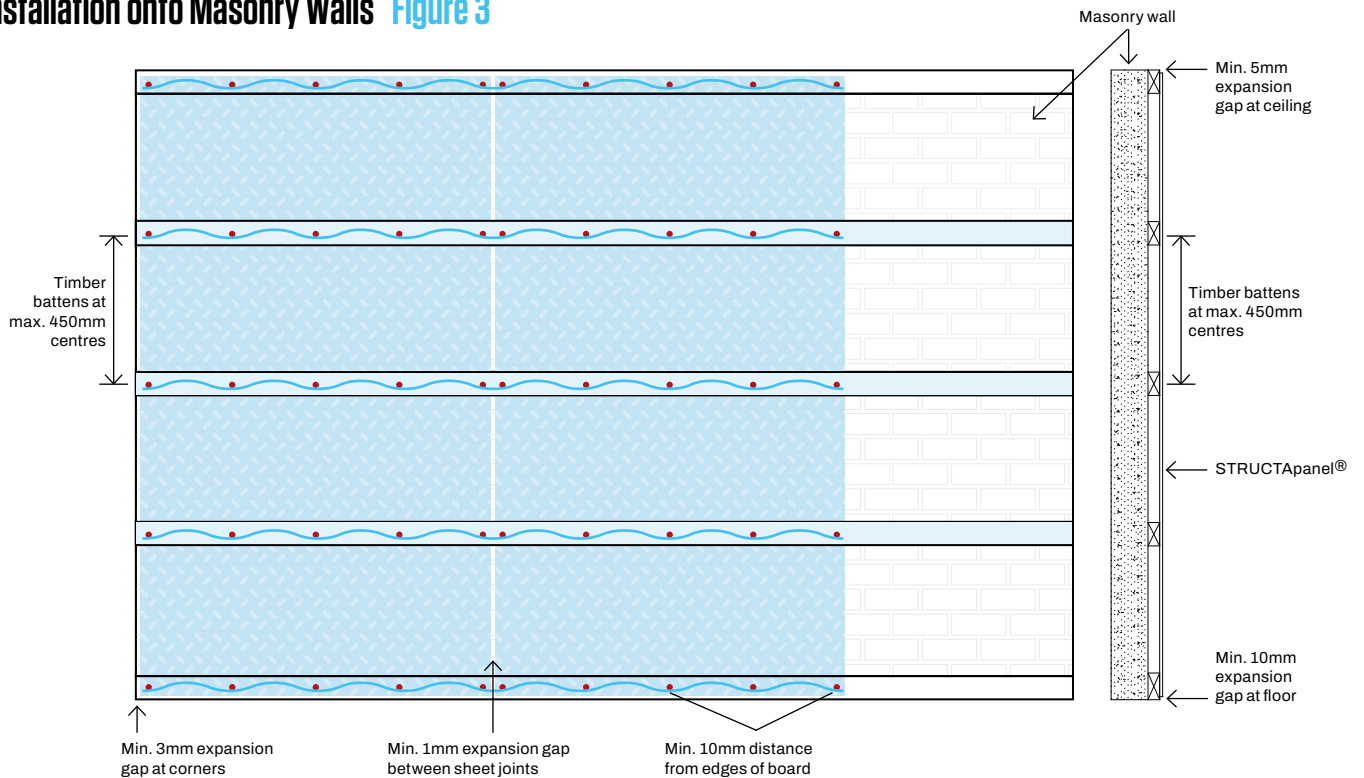

Installation onto Ceilings **Figure 4**

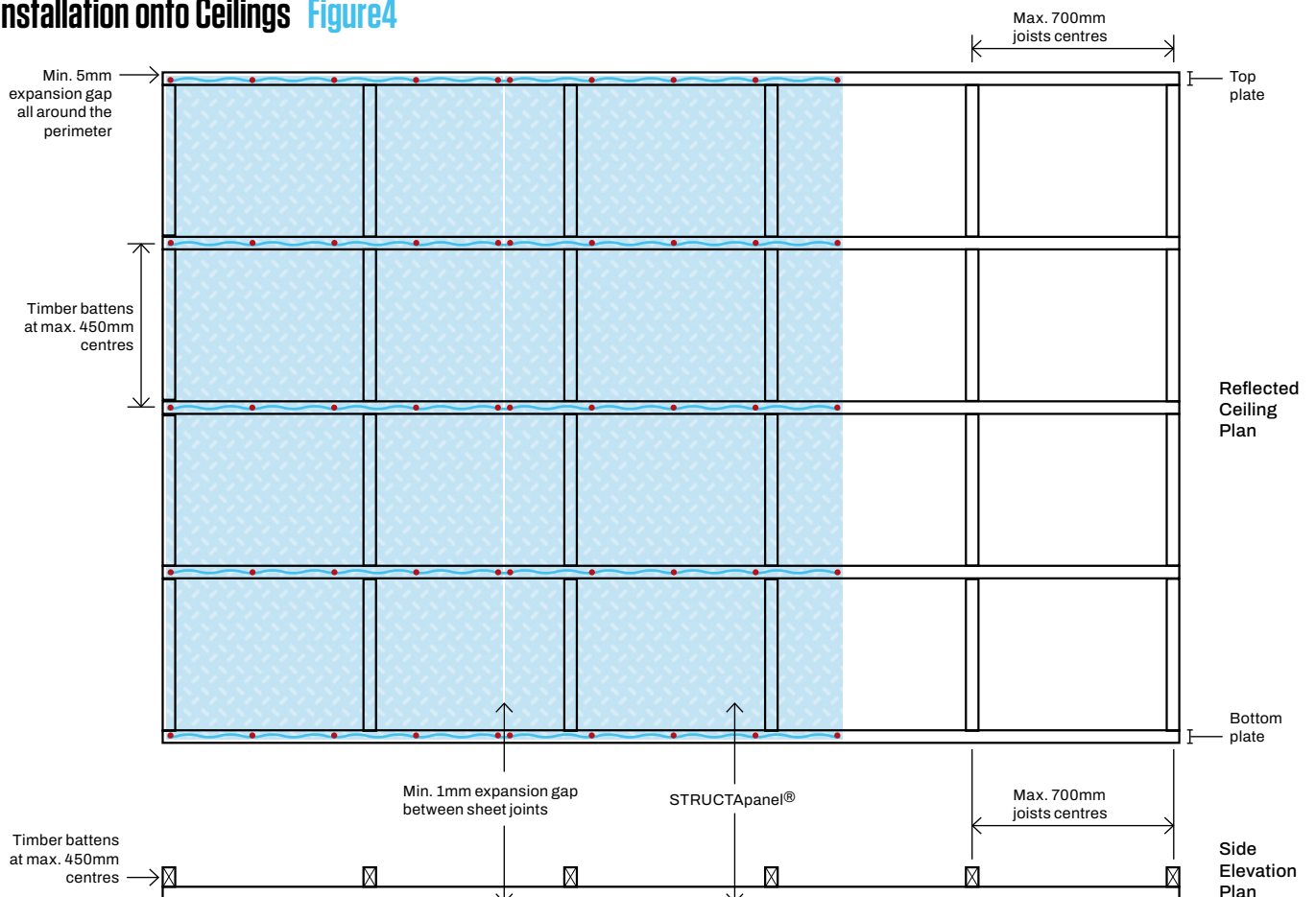

Diagram Legend

- STRUCTApanel®
- Glue
- Glue
- Fixings

Smooth, Black, T&G VJ150

INSTALLATION

Installation over the top of Plasterboard and other Existing Wall Linings **Figure 5**

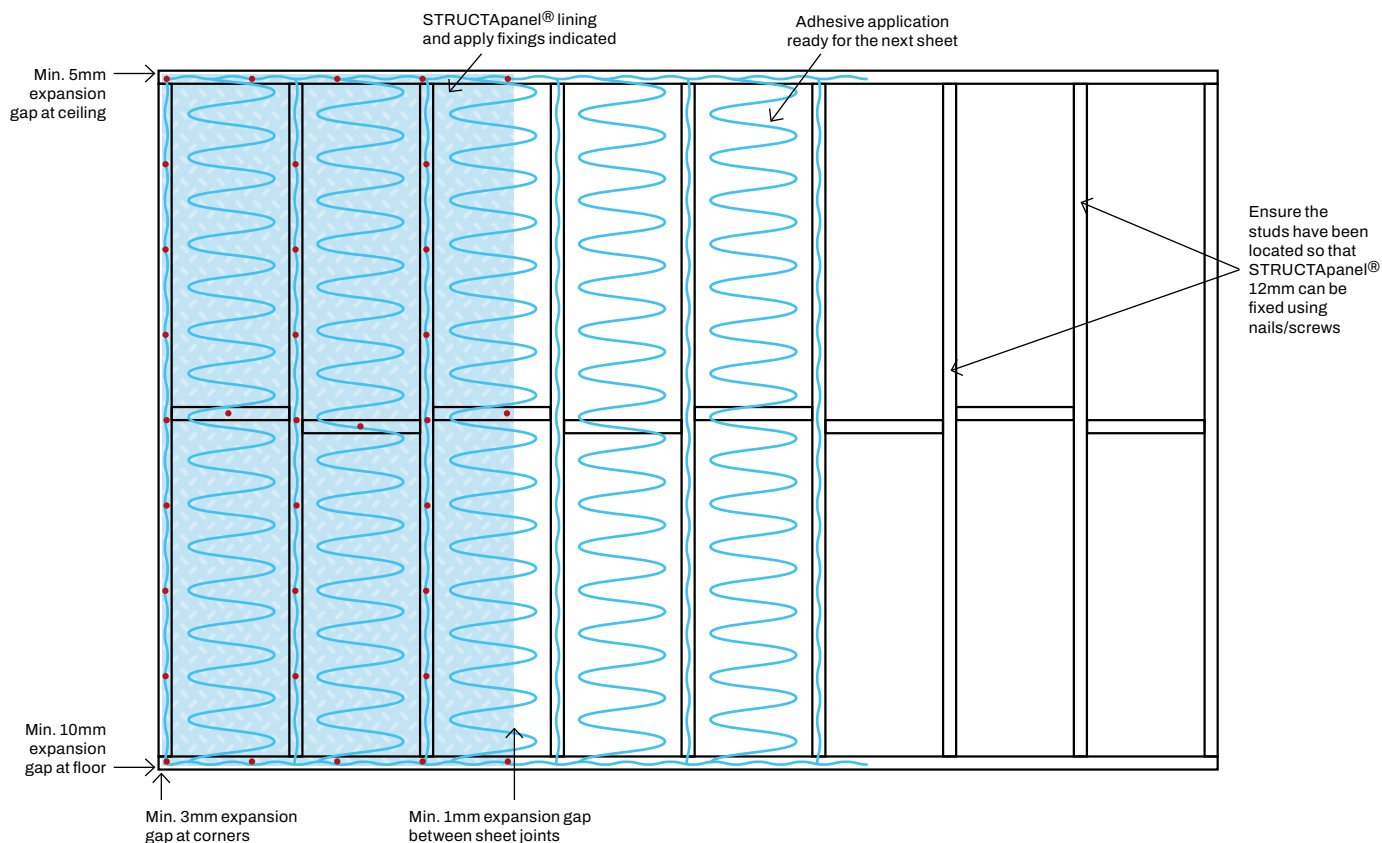

Installation of Panels Horizontally **Figure 6**

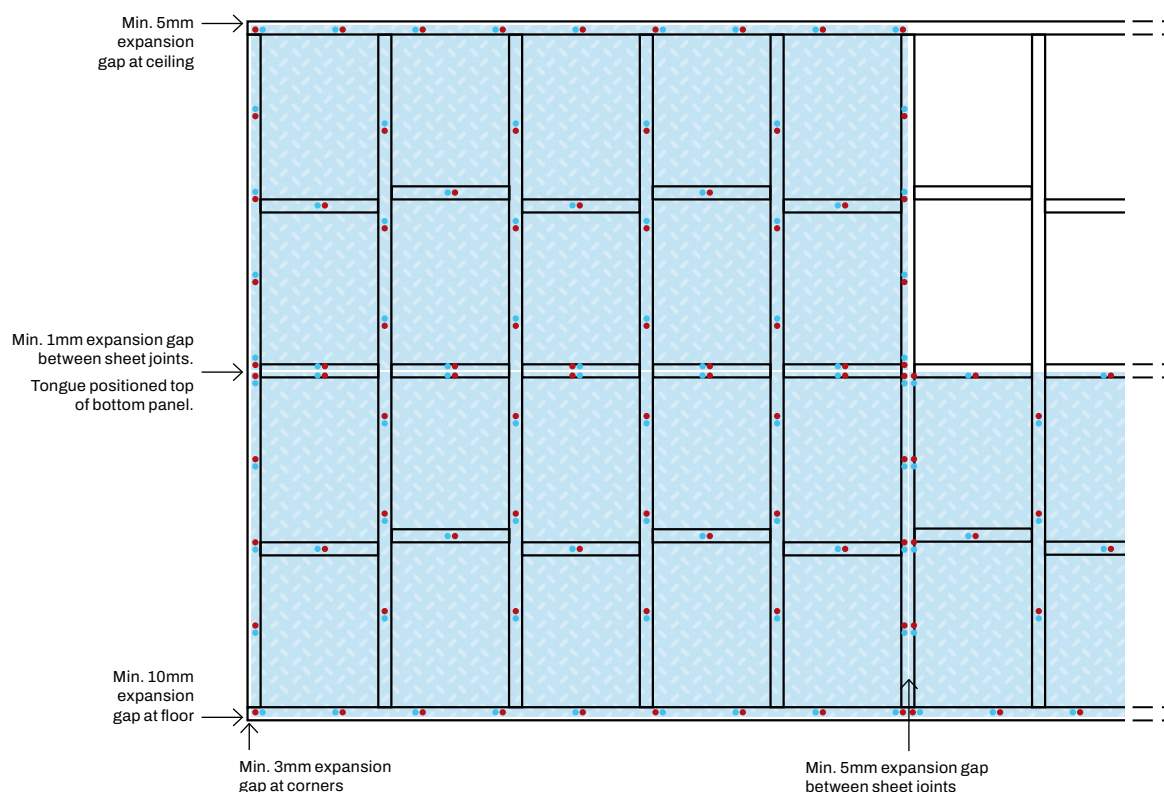

Smooth, Black, T&G VJ150

INSTALLATION

Installation of Partial Height Panels **Figure 7**

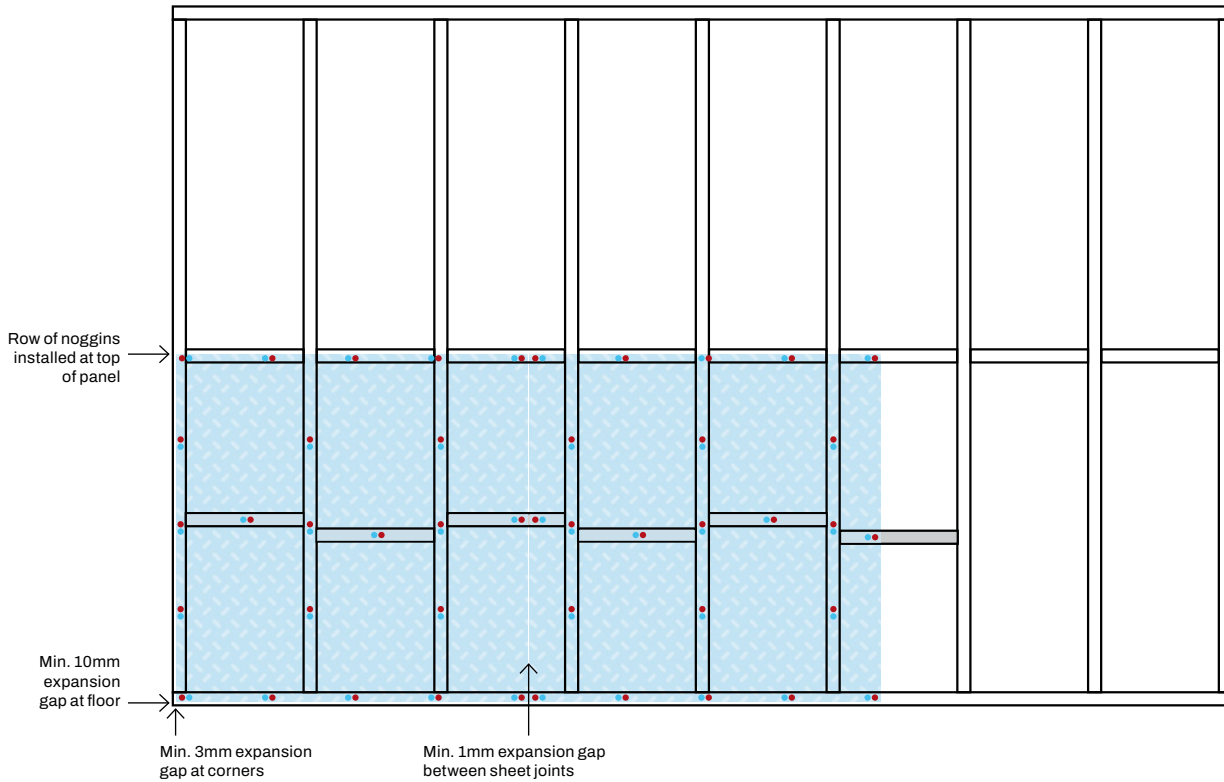

Installation of Mouldings, Cornices, Skirtings & Architraves **Figure 8**

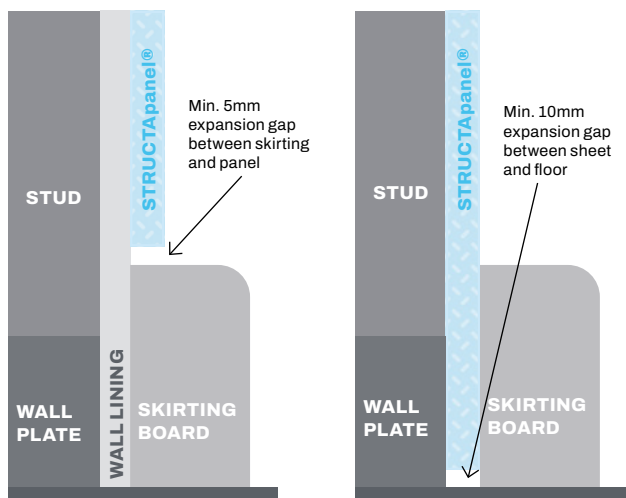

Installing Panels End to End **Figure 9**

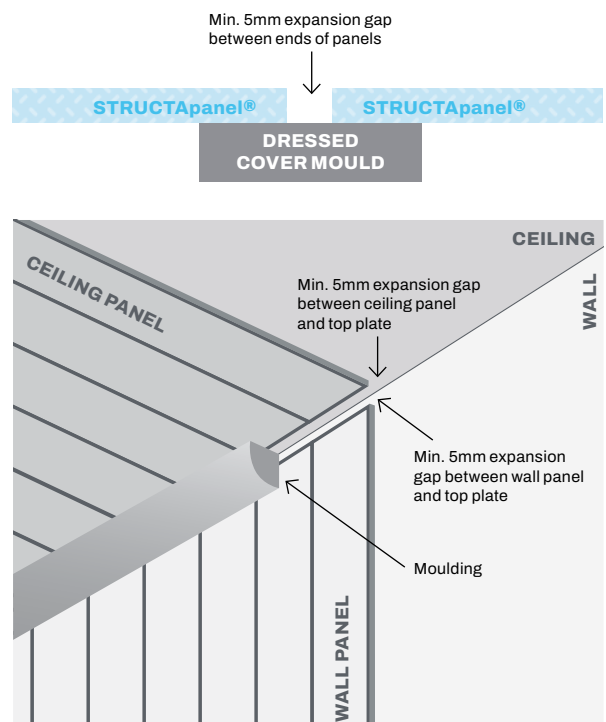

Smooth, Black, T&G VJ150

INSTALLATION

Installing around Fireplaces and Heat Sources **Figure 10**

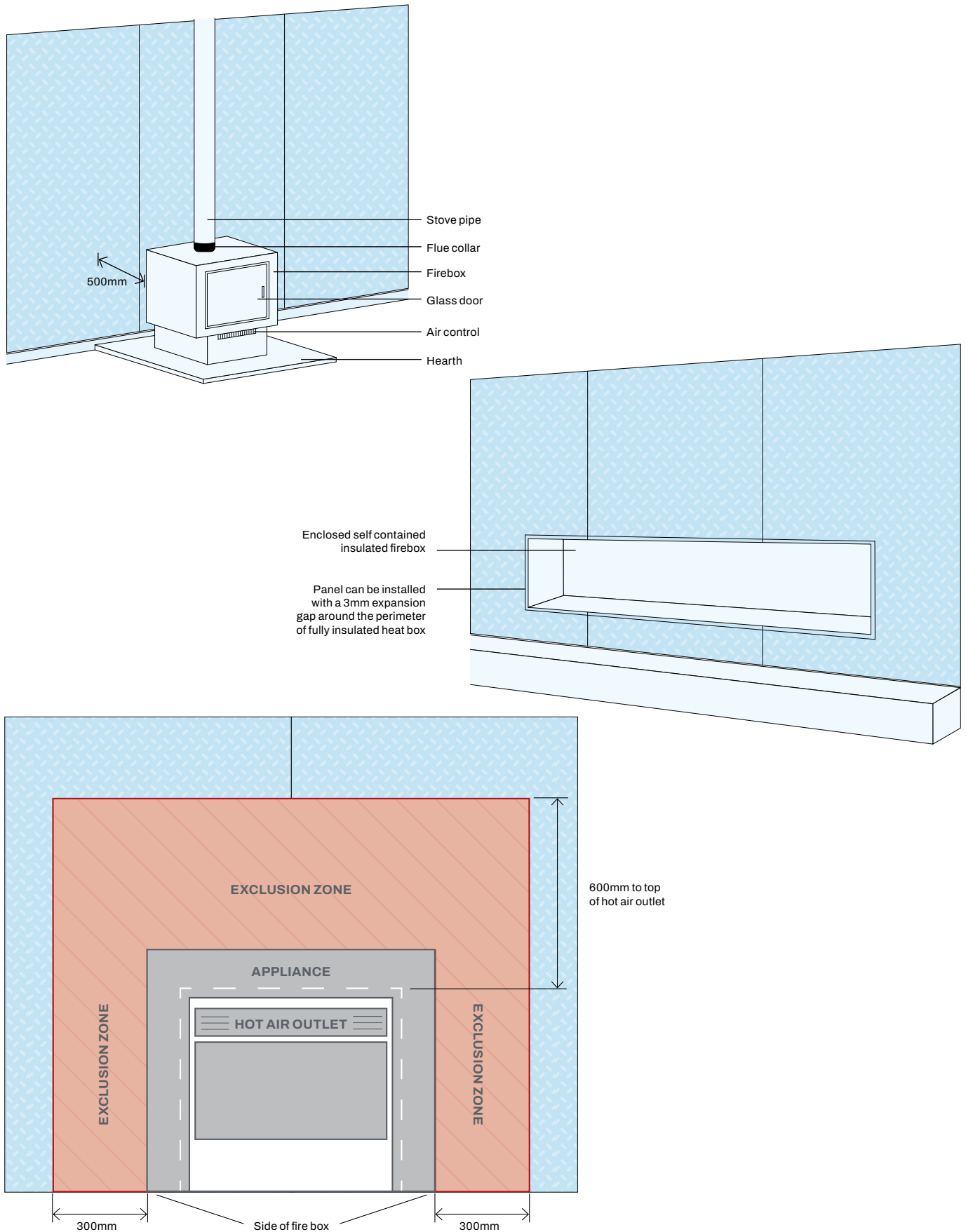

Smooth, Black, T&G VJ150

INSTALLATION

Cornice, Mouldings, Skirting and Architrave Ideas **Figure 11**

Skirting

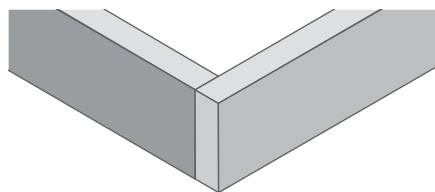

Butt

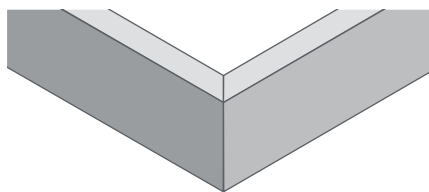

Mitre

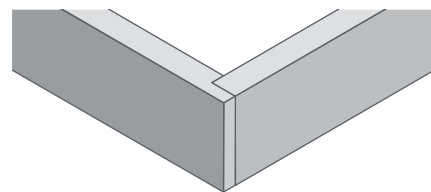

Rebated

Mouldings

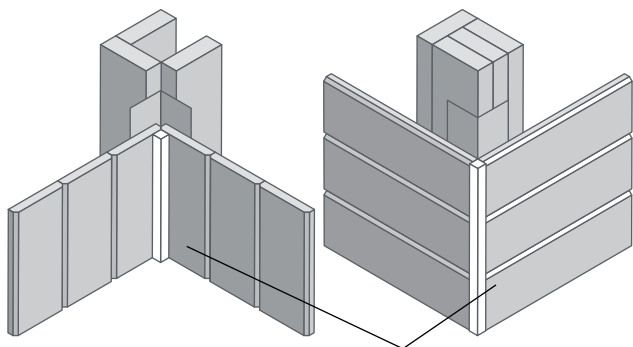

Internal and external corners using DAR Stops

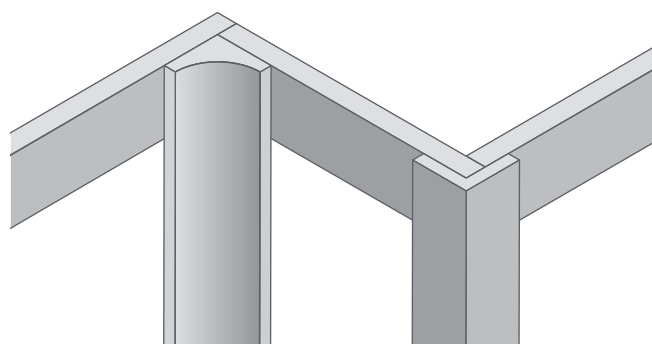

Internal and external corner moulding

Below are examples of products available from your local reseller that can complement and enhance your panel project.

Porta offers an extensive range of MDF and timber mouldings, which can be viewed on our website.

www.porta.com.au/products/mouldings/general-purpose-mouldings

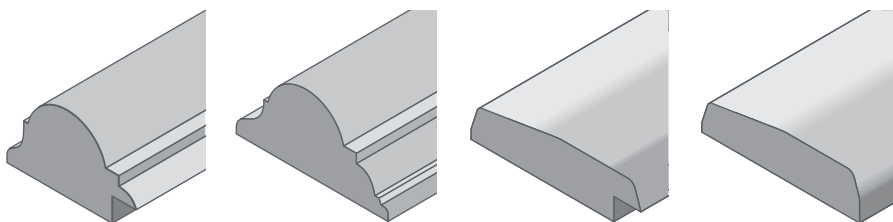

Timber Mouldings

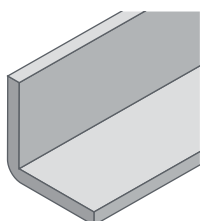

External Corner

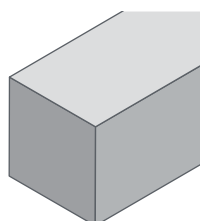

DAR Stop

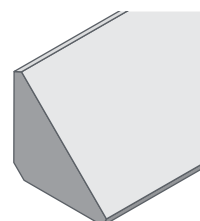

Tri-Quad Corner Moulding

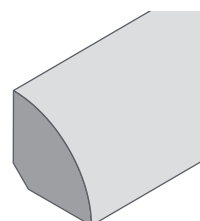

Quad Corner Moulding

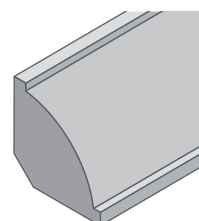

Ovolo Corner Moulding

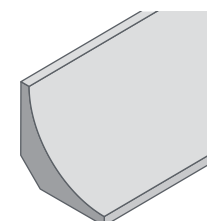

Scotia Corner Moulding

Smooth, Black, T&G VJ150

JOINING OPTIONS



Plastic End Cap



Timber Cover Strip



Plastic Shadowline Joiner



Plastic H Mould



Aluminium Internal Corner



Timber Quarter Round



Timber Cover Strip



Timber Tri Quad Cover Strip

Smooth, Black, T&G VJ150

BRACING INSTALLATION

Key Points

- STRUCTApanel® is termite treated
- Formaldehyde emission meets the E1 general purpose requirement
- PEFC Certified
- Complies with BCA
- Durable to weather conditions
- STRUCTApanel® complies with Australian Standards AS 1720.1 and AS 1684, parts 2 and 3
- Made in Australia from Plantation Radiata Pine for Australian houses and conditions
- Maximum 7.2kN/m racking resistance

Storage and Handling

If STRUCTApanel® is being used as an internal wall lining then the product should be kept dry at all times and not stored outside.

STRUCTApanel® should be allowed to acclimatise for 48 hours prior to installing. Minor movement can be expected in both vertical and horizontal sections of the board as it reaches its final resting moisture content (or EMC of the Site).

Termite Risk Management

STRUCTApanel® is available with H2 treatment. It is resistant to termites both north and south of the Tropic of Capricorn.



Smooth, Black, T&G VJ150

BRACING INSTALLATION

Fastener Recommendation

Racking resistance capacities of the STRUCTApanel® systems in this guide have been tested using 38mm x 2.8 dia flat head galvanised nails for 9mm, and 40mm x 2.8 dia flat head galvanised nails for 12mm. Power driven nails, with equivalent or better characteristic strengths can be substituted, as detailed in AS 1684.

For 9mm, 38mm long (1.59x1.35mm) BeA staples can be used, the spacings for staples are two thirds (i.e. fastener spacing multiplied by 0.66) those shown for nails or screws.

A minimum 2mm expansion gap must be allowed around the full perimeter of each panel and at any butt joint between STRUCTApanel® to allow for hygroscopic movement.

Fasteners with the equivalent dimensions, head size and shape, shank diameter and length to the fixing mentioned above are deemed acceptable.

Racking Performance

STRUCTApanel® is certified to achieve racking strengths as indicated in the table below when installed.

Bracing designed using timber framing from joint group JD5. No reduction factors need to be applied.

If outside AS 1684–2010, a suitable qualified professional engineer should be consulted to determine the correct wind speed from AS 4055–2012 or directly from AS 1170.2–2006.

STRUCTApanel® has been designed and independently tested and verified to AS 1684–2010.

Capacity Chart

Description	Racking Capacity kN/m	Reference to AS1684 min. panel width mm
System 1 – TYPE A		
With nominal fixings	3.4	900
System 2 – TYPE B		
With vertical M12 tie rods	6.4	900
System 3 – TYPE C		
With nominal fixings	6.0	900
System 4 – TYPE D		
With vertical M12 tie rods	7.2	900
System 5 – TYPE E		
Shortwall with coach screws	2.2	450
Shortwall with M12 tie rods	3.2	450

Cutting and Drilling

A hole 100mm x 100mm maximum within envelope of 100mm from top and vertical edges and 200mm of the bottom of the bracing panel will not significantly affect the bracing capacity. Up to 4 small circular service holes are allowable within the envelope but their centres must not be closer than 600mm.

Standard hand and power tools can be used to shape or cut STRUCTApanel®. Ensure blades or cutters are sharp to ensure a clean cut is achieved. Ensure all relevant PPE equipment is worn when cutting.

The normal health and safety precautions should be taken when working with wood panel products. Machine tools should be fitted with dust extractors and work areas kept clean. If dust levels exceed Worksafe Australia standards, the wearing of a dust mask (AS/NZS 1715 and AS/NZS 171) and safety glasses (AS/NZS 1337) is recommended.

Storage and work areas should be adequately ventilated.

Anchoring

Anchoring of bottom plates shall be in accordance with AS 1684 or designed in accordance with the relevant standard.

Additional fixings (cyclone rods) may be required to resist uplift forces and must be appropriately designed and installed.

Brick Ties

When used in the cavity of a brick veneer building, brick wall ties must be of the face-fixed type complying with AS 2699. The ties should be nailed through the STRUCTApanel® particleboard bracing to the face of the stud.

Bracing Installation Methods

The allowable racking resistance for Systems 1 to 5, in the following pages, have been tested with bracing applied to one side only. If STRUCTApanel® is applied to both sides of the wall frame, then racking resistance can be doubled, provided bottom plate fixing/hold-down requirements are also doubled. Bottom plate sizing may require checking to ensure hold-down compliance. Bracing design capacities are valid for wall heights up to 2700mm. For wall heights above 2700mm refer to AS 1684 section 8.3.6.4 for applicable reduction factors, as an example the current reduction factor for a 3m bracing panel = 0.9.

Note: For all the bracing systems, STRUCTApanel® has been tested using timber framing with a minimum joint strength of JD5. Therefore no reduction factors need to be calculated for JD5 framing timber. AS 1684 Section 8.3.6.5 specifies that bracing capacity is reduced by 50% for bracing widths of 600mm in length and increases linearly in capacity up to full capacity at 900mm bracing width.

No noggins are required when using full height bracing sheets, unless being used as internal bracing.

Smooth, Black, T&G VJ150

BRACING INSTALLATION

System 1: 3.4kN/m

Installation method:

- Fixing centres:
 - 150mm for top and bottom plates
 - 150mm for vertical edges
 - 300mm for intermediate studs
- Allow 2mm expansion gap around perimeter of each panel
- Minimum bracing section 900mm
- For bracing panel length between 600mm and 900mm the capacity shall be calculated by multiplying the respective capacities by 0.5 adjusted linearly to 1.0 for 900mm
- For panel lengths less than 900mm refer to AS1684 for further detail

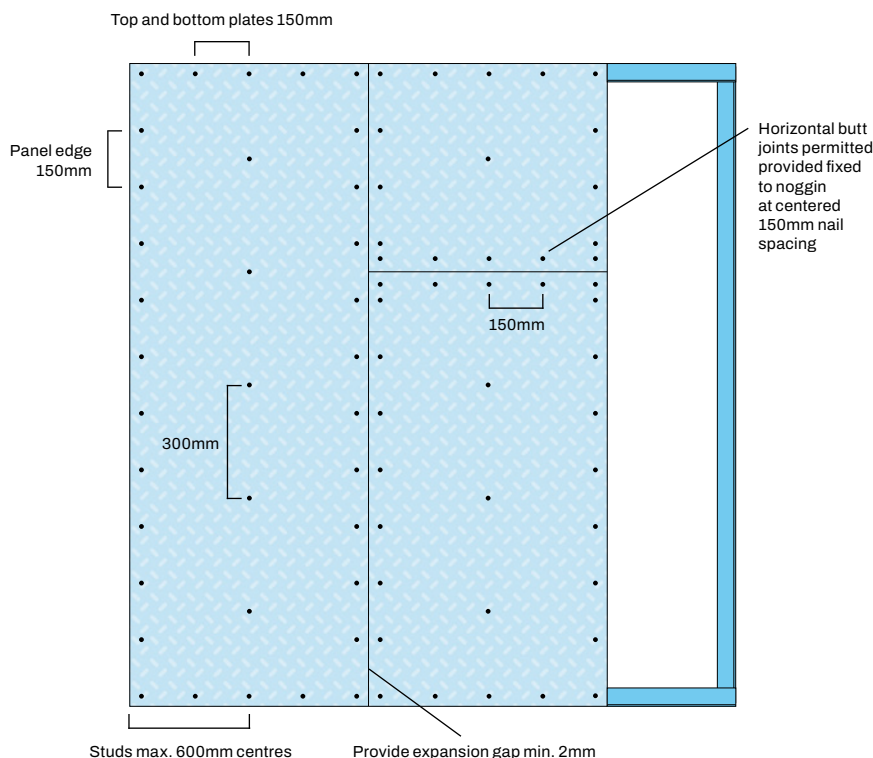

System 2: 6.4kN/m

Installation method:

- Fixing centres:
 - 150mm for top and bottom plates
 - 150mm for vertical edges
 - 300mm for intermediate studs
- M12 tie rods from top plate to floor or slab at each end of sheathed section
- Allow 2mm expansion gap around perimeter of each panel
- Minimum bracing section 900mm
- Anchors fixing the bottom plate to the floor or slab rated to 13kN at 1200mm maximum centres

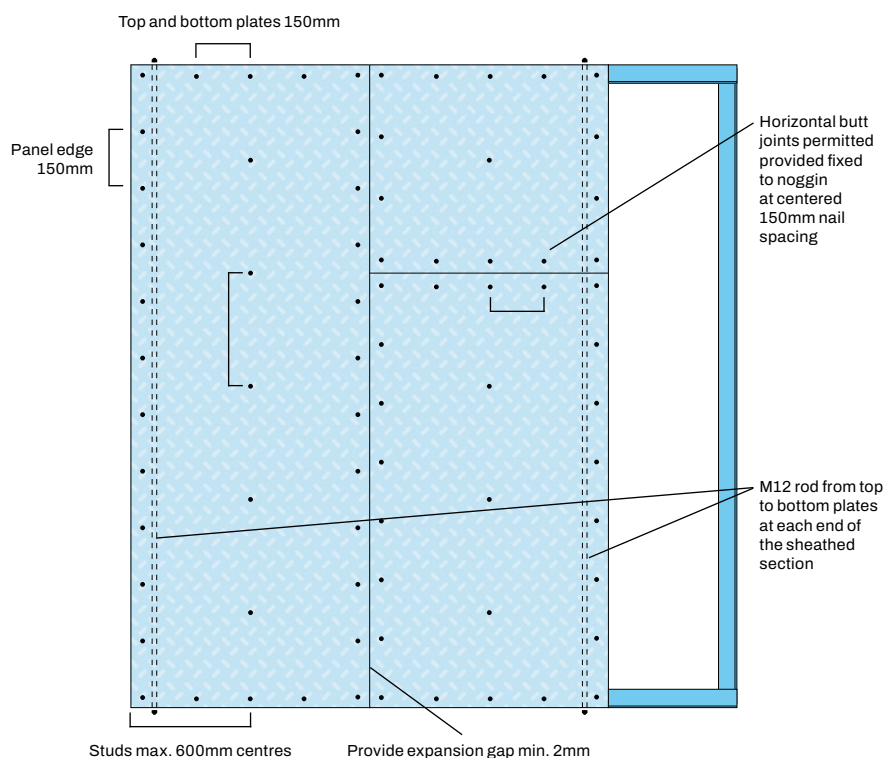

Smooth, Black, T&G VJ150

BRACING INSTALLATION

System 3: 6.0kN/m

Installation method:

- Fixing centres:
 - 50mm for top and bottom plates
 - 150mm for vertical edges
 - 300mm for intermediate studs
- Allow 2mm expansion gap around perimeter of each panel
- Minimum bracing section 900mm
- Anchors fixing the bottom plate to the floor or slab rated to 13kN at 1200mm maximum centres

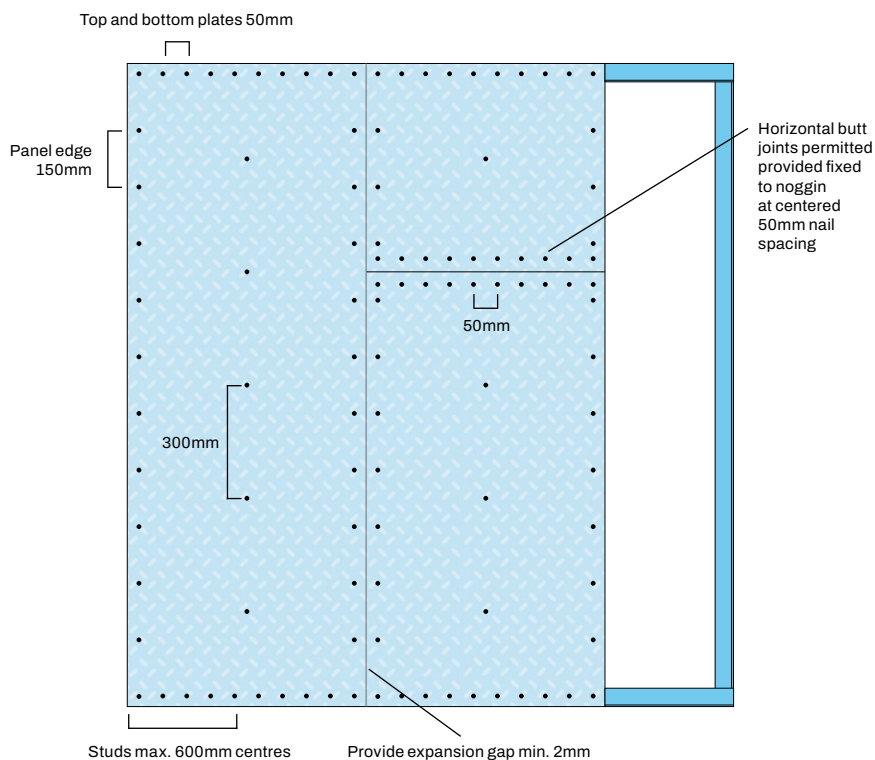

System 4: 7.2kN/m

Installation method:

- Fixing centres:
 - 50mm for top and bottom plates
 - 150mm for vertical edges
 - 300mm for intermediate studs
- M12 tie rods from top plate to floor or slab at each end of sheathed section
- Allow 2mm expansion gap around perimeter of each panel
- Minimum bracing section 900mm
- Anchors fixing the bottom plate to the floor or slab rated to 13kN at 1200mm maximum centres

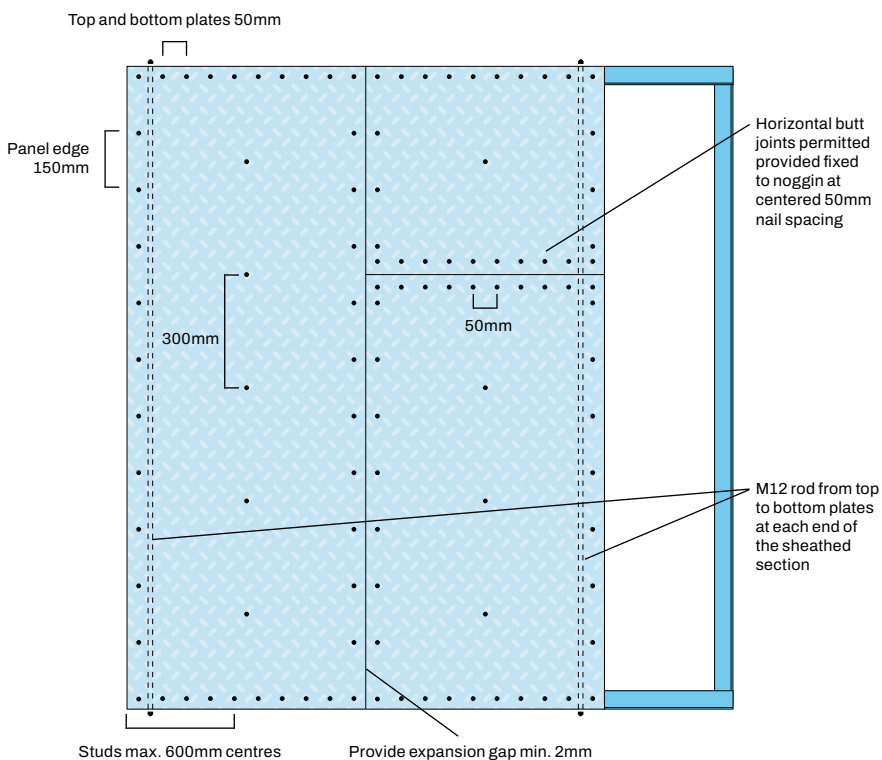

Smooth, Black, T&G VJ150

BRACING INSTALLATION

System 5: 2.2kN/m

Installation method:

- Fixing centres:
 - 150mm for top and bottom plates
 - 150mm for vertical edges
- M10 x 70mm coach screws with 50 x 50 x 3mm washers in each corner of sheathed section

Alternate installation method:

- Fixing centres:
 - 50mm for top and bottom plates
 - 150mm for vertical edges
- M12 tie rods at each end of short wall sheathed section to achieve 3.2kN/m
- Minimum bracing section 450mm
- Refer to AS 1684 Section 8.3.6.5 for further details

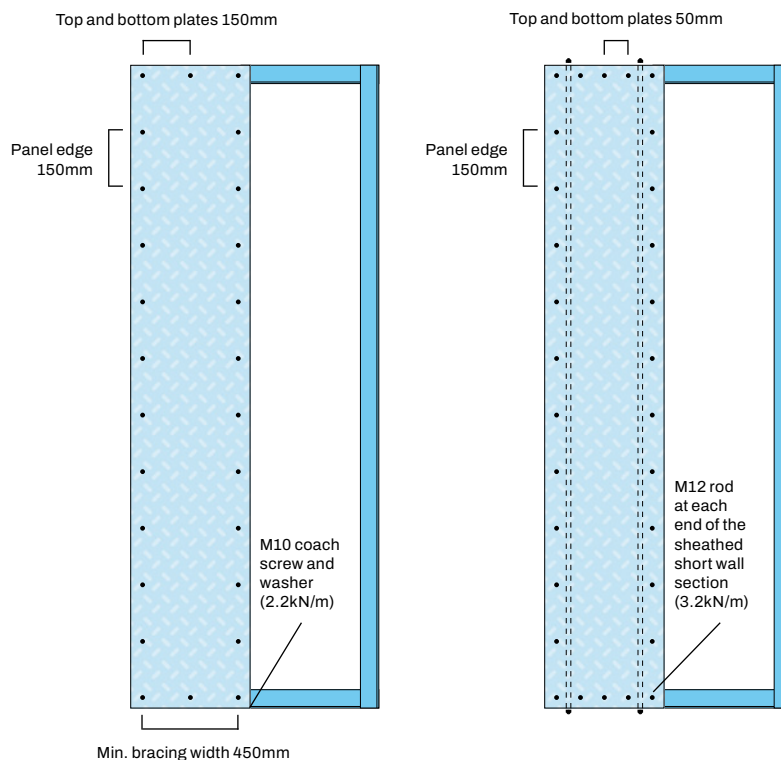

Smooth 12mm, Black

TEMPORARY HOARDING PANELLING

Temporary Hoarding Panelling

Tools Required

- Screw gun
- String line
- Straight edge
- Screws – A min. of 5 x type 17 – 14g x 50mm self tapping galvanized wood screws or similar

Installation

- STRUCTApanel® should be stored dry before fixing onto hoarding framework
- When storing outside, ensure packs are kept clear off the ground. Cover with waterproof sheeting laid on evenly spaced timber battens so that air circulates freely between the waterproof cover and the product

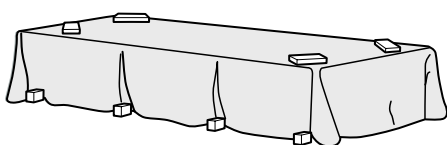

- STRUCTApanel® 12mm should be fixed to a min. of 3 rails, top / middle and bottom of sheet
- STRUCTApanel® 12mm should have a gap at the bottom of at least 20mm from the ground and shouldn't be able to constantly be in contact with pooling water, soil, etc
- STRUCTApanel® 12mm should not have other materials pushed up against it, including landscaping, garden material, etc
- A min. of 5 x type 17 – 14g x 50mm self tapping galvanized wood screws or similar should be used to fix the STRUCTApanel® to each rail with the screws on each edge being a min. of 20mm from the edge
- A 3mm expansion gap should be placed between each panel
- Screws should be checked and re-tightened if required during the time the hoarding is erected

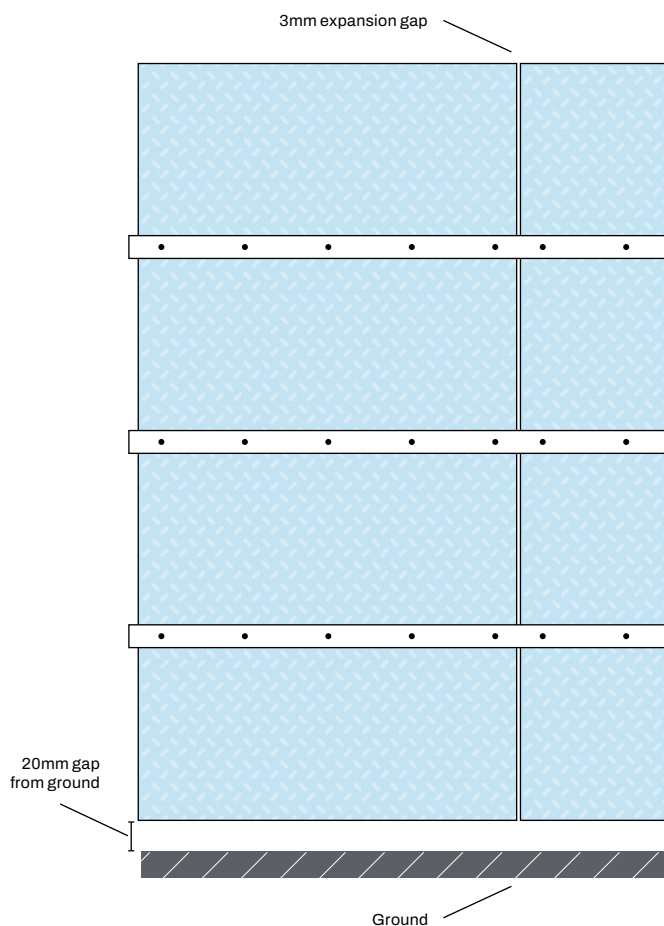

Smooth 12mm

TIMBER FLOORING UNDERLAY

Laying over concrete and under timber strip flooring

1. Concrete Preparation

- All slab should be flat with no more than 3mm below a straight edge spanning between two high points 1.5m apart
- If the concrete slab is not flat then surface preparation such as grinding or levelling is needed
- Concrete moisture content should be less than 4%
- Slabs on the ground should be constructed with a continuous under slab vapour barrier (in accordance with AS 2780)



2. Acclimatisation

- STRUCTApanel® should be allowed to acclimatise to the rooms normal in service EMC
- STRUCTApanel® should remain dry at all times



3. Laying a Moisture Vapour Barrier Underneath

- A minimum 0.2m plastic moisture vapor barrier should be laid on top of the concrete slab, with joints overlapped by 300mm and taped. Plastic should go up the wall to above the height of the top surface of STRUCTApanel®

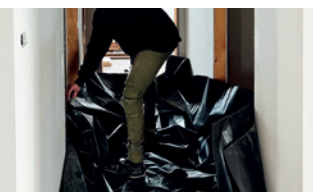

4. Installing STRUCTApanel® 12mm

- Lay in a brick shaped pattern
- Expansion gaps:
 - 10mm around the outside of perimeter walls or fixtures,
 - 3–5mm between the edges of each sheet

- Max. expansion gaps (5mm) can be used in high humidity conditions
- Min. expansion gaps (3mm) can be used in low humidity conditions



5. Fixings

- Appropriate anti rust concrete fixings should be positioned approx. 50mm in from edges of sheet, and approx. 380mm apart i.e. approx. 7 rows down the panel length and 4 rows across the panel width
- Fix sheets through the membrane to the slab with hand driven 50mm long by 6.5mm spikes (Powers SPIKE), or masonry split anchors 50mm long by 6mm, or equivalent
- Heads should be positioned under the surface of the panel to allow for sanding

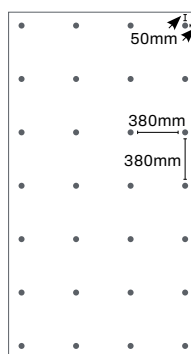

6. Laying of Timber Strip Flooring

- Timber strip flooring should be laid following manufacturer's recommendations

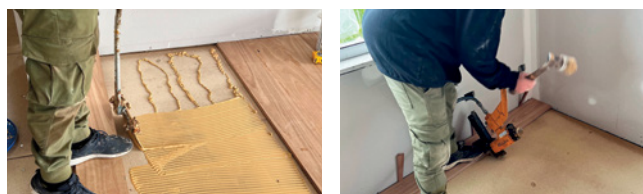

7. Sealing of Timber Strip Flooring



Note: STRUCTApanel® is structurally certified for bracing only.

Smooth 9mm

CERTIFICATION

Bracing using staples



Certificate of Structural Performance

Porta Products P/L 9mm Structapanel- square flat edge.

The design methodology and criteria for applications using the 9mm Structapanel™ panels are based upon the results of full scale testing undertaken in 2020 at the Queensland University of Technology and previous work by the Plywood Association of Australia, and have been prepared in accordance with widely recognised engineering principles and are based upon use of the following documents:

1. AS1684 – 2021 SAA National Timber Framing Code
2. AS1720.1 – 2010 SAA Timber Structures Code – Part 1 Design Methods

When installed in accordance with the manufacturer's specification using 38mm long (1.59x1.35mm) BeA staples, 9mm Structapanel™ panels will comply with the requirements of the Building Code of Australia. The certified design properties (derived from full scale testing) for walls up to 2.7m in height, constructed of timber framing of grade JD5 (MGP10) or better, (using 2400 x 900, 2400 x 1200, 2700 x 900 and 2700 x 1200 panels) are as follows, when such loads are determined in accordance with AS1170 (parts 1 - 4):

Type 1 panels: 100/100/200 – WITHOUT tie down rods: minimum racking resistance of 3.4 kN/m

- nailing pattern and nominal fixings of the bottom plate to the floor or slab are similar to Detail (g), Table 8.18, Parts 2 and 3, AS1684.

Type 2 panels: 100/100/200 – WITH M12 tie down rods: minimum racking resistance of 6.4 kN/m

- M12 tie-down rods at each end of the braced wall, with anchors rated to 13kN at 1200mm c/c maximum spacings, and
- nailing pattern similar to Method A, Detail (h), Table 8.18, Parts 2 and 3, AS1684.

Type 3 panels: 30/100/200 – WITHOUT tie down rods: minimum racking resistance of 6.0 kN/m

- nailing pattern and anchors rated to 13kN at 1200mm maximum spacings similar to Method B, Detail (h), Table 8.18, Parts 2 and 3, AS1684.

Type 4 panels: 30/100/200 – WITH M12 tie down rods: minimum racking resistance of 7.2 kN/m

- M12 tie-down rods at each end of the braced wall, with anchors rated to 13kN at 1200mm c/c maximum spacings.

Product substitution is permitted for panel products of equivalent or lesser bracing capacity. This includes plywood (9mm F8; 7mm F11; 6mm F14; 4.5mm F27) and hardboard (4.5mm) products noted in Table 8.18 of AS 1684 – 2021 (Parts 2 and 3). 9mm Structapanel™ panels can also be used for short panels in accordance with AS1684 Section: 8.3.6.5, which specifies that the bracing capacity is reduced by 50% for walls of 600mm length, with a linear increase in capacity up to full capacity at 900mm length.

Yours sincerely

Prof Keith Crews BE(hons) ME PhD

FIEAust CPEng RPEQ NER (ret)

Professor & Director

ARC Industrial Transformation Research Hub to Advance Timber for Australia's Future Built Environment

Emeritus Professor of Structural Engineering – University of Technology Sydney

December 17, 2025

Smooth 9mm

CERTIFICATION

Bracing using nails or screws



Certificate of Structural Performance

Porta Products P/L 9mm Structapanel- square flat edge.

The design methodology and criteria for applications using the 9mm Structapanel™ panels are based upon the results of full scale testing undertaken in 2020 at the Queensland University of Technology, and have been prepared in accordance with widely recognised engineering principles and are based upon use of the following documents:

1. AS1684 – 2021 SAA National Timber Framing Code
2. AS1720.1 – 2010 SAA Timber Structures Code – Part 1 Design Methods

When installed in accordance with the manufacturer's specification using 35mm long nails, 9mm Structapanel™ panels will comply with the requirements of the Building Code of Australia. The certified design properties (derived from full scale testing) for walls up to 2.7m in height, constructed of timber framing of grade JD5 (MGP10) or better, (using 2400 x 900, 2400 x 1200, 2700 x 900 and 2700 x 1200 panels) are as follows, when such loads are determined in accordance with AS1170 (parts 1 - 4):

- Type 1 panels: 150/150/300 – WITHOUT tie down rods: minimum racking resistance of 3.4 kN/m
- nailing pattern and nominal fixings of the bottom plate to the floor or slab are similar to Detail (g), Table 8.18, Parts 2 and 3, AS1684.
- Type 2 panels: 150/150/300 – WITH M12 tie down rods: minimum racking resistance of 6.4 kN/m
- M12 tie-down rods at each end of the braced wall, with anchors rated to 13kN at 1200mm c/c maximum spacings, and
 - nailing pattern similar to Method A, Detail (h), Table 8.18, Parts 2 and 3, AS1684.
- Type 3 panels: 50/150/300 – WITHOUT tie down rods: minimum racking resistance of 6.0 kN/m
- nailing pattern and anchors rated to 13kN at 1200mm maximum spacings similar to Method B, Detail (h), Table 8.18, Parts 2 and 3, AS1684.
- Type 4 panels: 50/150/300 – WITH M12 tie down rods: minimum racking resistance of 7.2 kN/m
- M12 tie-down rods at each end of the braced wall, with anchors rated to 13kN at 1200mm c/c maximum spacings.

Product substitution is permitted for panel products of equivalent or lesser bracing capacity. This includes plywood (9mm F8; 7mm F11; 6mm F14; 4.5mm F27) and hardboard (4.5mm) products noted in Table 8.18 of AS 1684 – 2021 (Parts 2 and 3). 9mm Structapanel™ panels can also be used for short panels in accordance with AS1684 Section: 8.3.6.5, which specifies that the bracing capacity is reduced by 50% for walls of 600mm length, with a linear increase in capacity up to full capacity at 900mm length.

Yours sincerely

Prof Keith Crews BE(hons) ME PhD

FIEAust CPEng RPEQ NER (ret)

Professor & Director

ARC Industrial Transformation Research Hub to Advance Timber for Australia's Future Built Environment

Emeritus Professor of Structural Engineering – University of Technology Sydney

December 17, 2025

CERTIFICATION

Bracing using nails and screws



Certificate of Structural Performance

Porta Products P/L 12mm Structapanel H2 - square flat edge (nail & screw fasteners)

The design methodology and criteria for applications using the 12mm Structapanel™ panels are based upon the results of full scale testing undertaken in 2020 at the Queensland University of Technology, and have been prepared in accordance with widely recognised engineering principles and are based upon use of the following documents:

1. AS1684 – 2021 SAA National Timber Framing Code
2. AS1720.1 – 2010 SAA Timber Structures Code – Part 1 Design Methods

When installed in accordance with the manufacturer's specification using 40mm long * 2.8mm diameter nails or 40mm long No 4 (2.74mm dia) screws, 12mm Structapanel™ panels will comply with the requirements of the Building Code of Australia. The certified design properties (derived from full scale testing) for walls up to 2.7m in height, constructed of timber framing of grade JD5 (MGP10) or better, (using 2400 x 900, 2400 x 1200, 2700 x 900 and 2700 x 1200 panels) are as follows, when such loads are determined in accordance with AS1170 (parts 1 - 4):

- Type 1 panels: 150/150/300 – WITHOUT tie down rods: minimum racking resistance of 3.4 kN/m
- nailing pattern and nominal fixings of the bottom plate to the floor or slab are similar to Detail (g), Table 8.18, Parts 2 and 3, AS1684.
- Type 2 panels: 150/150/300 – WITH M12 tie down rods: minimum racking resistance of 6.4 kN/m
- M12 tie-down rods at each end of the braced wall, with anchors rated to 13kN at 1200mm c/c maximum spacings, and
 - nailing pattern similar to Method A, Detail (h), Table 8.18, Parts 2 and 3, AS1684.
- Type 3 panels: 50/150/300 – WITHOUT tie down rods: minimum racking resistance of 6.0 kN/m
- nailing pattern and anchors rated to 13kN at 1200mm maximum spacings similar to Method B, Detail (h), Table 8.18, Parts 2 and 3, AS1684.
- Type 4 panels: 50/150/300 – WITH M12 tie down rods: minimum racking resistance of 7.2 kN/m
- M12 tie-down rods at each end of the braced wall, with anchors rated to 13kN at 1200mm c/c maximum spacings.

Product substitution is permitted for panel products of equivalent or lesser bracing capacity. This includes plywood (9mm F8; 7mm F11; 6mm F14; 4.5mm F27) and hardboard (4.5mm) products noted in Table 8.18 of AS 1684 – 2021 (Parts 2 and 3). 9mm Structapanel™ panels can also be used for short panels in accordance with AS1684 Section: 8.3.6.5, which specifies that the bracing capacity is reduced by 50% for walls of 600mm length, with a linear increase in capacity up to full capacity at 900mm length.

Yours sincerely

Prof Keith Crews BE(hons) ME PhD

FIEAust CPEng RPEQ NER (ret)

Professor & Director

ARC Industrial Transformation Research Hub to Advance Timber for Australia's Future Built Environment

Emeritus Professor of Structural Engineering – University of Technology Sydney

December 17, 2025

CERTIFICATION

Bracing using nails, screws and glue



Certificate of Structural Performance

Porta Products P/L 12mm Structapanel H2 - square flat edge (Brad nail fasteners).

The design methodology and criteria for applications using the 12mm Structapanel™ panels are based upon the results of full scale testing undertaken in 2020 at the Queensland University of Technology, and have been prepared in accordance with widely recognised engineering principles and are based upon use of the following documents:

1. AS1684 – 2021 SAA National Timber Framing Code
2. AS1720.1 – 2010 SAA Timber Structures Code – Part 1 Design Methods

When installed in accordance with the manufacturer's specification using 38mm long Brad nails, 12mm Structapanel™ panels will comply with the requirements of the Building Code of Australia. The certified design properties (derived from full scale testing) for walls up to 2.7m in height, constructed of timber framing of grade JD5 (MGP10) or better, (using 2400 x 900, 2400 x 1200, 2700 x 900 and 2700 x 1200 panels) are as follows, when such loads are determined in accordance with AS1170 (parts 1 - 4):

Type 1 panels: Sheathing on one side only: minimum racking resistance of 2.0 kN/m

- 1.6 (ϕ) x 38mm (l) brad nails at 450mm spacings, dobs of construction adhesive at 450mm spacings and nominal fixings of the bottom plate to the floor or slab.

Type 2 panels: Sheathing on both sides: minimum racking resistance of 3.4 kN/m

- 1.6 (ϕ) x 38mm (l) brad nails at 450mm spacings, dobs of construction adhesive at 450mm spacings and nominal fixings of the bottom plate to the floor or slab.

Type 3 panels: Sheathing on both sides: minimum racking resistance of 4.0 kN/m

- 1.6 (ϕ) x 38mm (l) brad nails at 450mm spacings, dobs of construction adhesive at 450mm spacings and a 13 kN capacity connection at each end and intermediately at max 1200mm spacings through the bottom plate into the floor or slab.

Product substitution is permitted for panel products of equivalent or lesser bracing capacity. This includes plywood (9mm F8; 7mm F11; 6mm F14; 4.5mm F27) and hardboard (4.5mm) products noted in Table 8.18 of AS 1684 – 2021 (Parts 2 and 3). 9mm Structapanel™ panels can also be used for short panels in accordance with AS1684 Section: 8.3.6.5, which specifies that the bracing capacity is reduced by 50% for walls of 600mm length, with a linear increase in capacity up to full capacity at 900mm length.

Yours sincerely

Prof Keith Crews BE(hons) ME PhD

FIEAust CPEng RPEQ NER (ret)

Professor & Director

ARC Industrial Transformation Research Hub to Advance Timber for Australia's Future Built Environment

Emeritus Professor of Structural Engineering – University of Technology Sydney

December 17, 2025

CERTIFICATION

Bracing using nails and screws



Certificate of Structural Performance

Porta Products P/L 12mm Structapanel H2 - grooved (nail & screw fasteners)

The design methodology and criteria for applications using the 12mm Structapanel™ panels are based upon the results of full scale testing undertaken in 2020 at the Queensland University of Technology, and have been prepared in accordance with widely recognised engineering principles and are based upon use of the following documents:

1. AS1684 – 2021 SAA National Timber Framing Code
2. AS1720.1 – 2010 SAA Timber Structures Code – Part 1 Design Methods

When installed in accordance with the manufacturer's specification using 40mm long * 2.8mm diameter nails or 40mm long No 4 (2.74mm dia) screws, 12mm Structapanel™ panels will comply with the requirements of the Building Code of Australia. The certified design properties (derived from full scale testing) for walls up to 2.7m in height, constructed of timber framing of grade JD5 (MGP10) or better, (using 2400 x 900, 2400 x 1200, 2700 x 900 and 2700 x 1200 panels) are as follows, when such loads are determined in accordance with AS1170 (parts 1 - 4):

Type 1 panels: 150/150/300 – WITHOUT tie down rods: minimum racking resistance of 3.4 kN/m

- nailing pattern and nominal fixings of the bottom plate to the floor or slab are similar to Detail (g), Table 8.18, Parts 2 and 3, AS1684.

Type 2 panels: 150/150/300 – WITH M12 tie down rods: minimum racking resistance of 6.4 kN/m

- M12 tie-down rods at each end of the braced wall, with anchors rated to 13kN at 1200mm c/c maximum spacings, and
- nailing pattern similar to Method A, Detail (h), Table 8.18, Parts 2 and 3, AS1684.

Type 3 panels: 50/150/300 – WITHOUT tie down rods: minimum racking resistance of 6.0 kN/m

- nailing pattern and anchors rated to 13kN at 1200mm maximum spacings similar to Method B, Detail (h), Table 8.18, Parts 2 and 3, AS1684.

Type 4 panels: 50/150/300 – WITH M12 tie down rods: minimum racking resistance of 7.2 kN/m

- M12 tie-down rods at each end of the braced wall, with anchors rated to 13kN at 1200mm c/c maximum spacings.

Product substitution is permitted for panel products of equivalent or lesser bracing capacity. This includes plywood (9mm F8; 7mm F11; 6mm F14; 4.5mm F27) and hardboard (4.5mm) products noted in Table 8.18 of AS 1684 – 2021 (Parts 2 and 3). 9mm Structapanel™ panels can also be used for short panels in accordance with AS1684 Section: 8.3.6.5, which specifies that the bracing capacity is reduced by 50% for walls of 600mm length, with a linear increase in capacity up to full capacity at 900mm length.

Yours sincerely

Prof Keith Crews BE(hons) ME PhD

FIEAust CPEng RPEQ NER (ret)

Professor & Director

ARC Industrial Transformation Research Hub to Advance Timber for Australia's Future Built Environment

Emeritus Professor of Structural Engineering – University of Technology Sydney

December 17, 2025

Porta is more than just a timber and panel supplier. We're a trusted partner, delivering purpose-driven products, reliable service, and local expertise. Proudly Australian, we're committed to lasting quality and progress.

The STRUCTA™ range is part of the Porta family. Built on generations of know-how, every product is engineered to perform under pressure and deliver the durability builders trust.

We've long been the backbone of the Australian building industry, driven by a genuine commitment to local manufacturing and getting the job done right. Strengthened by our STRUCTA™ range, we are continuing that legacy and setting the standard for structural building solutions.

Performance you can count on, powered by local knowledge and made to keep your projects moving with confidence.

porta

© Porta Products Pty. Ltd.
Every effort has been made to ensure the information in this brochure is correct. Porta Products reserves the right to modify or delete products at any time as a part of the product development process. Printed colours are indicative only. Any information, claims or pricing needs to be confirmed at the time and point of purchase.

1300 500 250 | porta.com.au

